



Slim Line Magnet Tank Cleaners

In-Line Magnets Standard or Heavy-Duty

The primary difference between slim line and regular tank cleaners is in the smaller diameter of the slim line. Capable of being inserted into a hole tapped for a 3/4" plug, the cleaner is especially useful in small reservoirs, gear boxes and other applications where space is at a premium.

Since there is a ratio between length and diameter of a magnet for greatest power, each unit is designed to give maximum magnetic power possible in a small space.

Slim Line Tank Cleaners are available in two models: standard and heavy-duty. Although the magnetic unit is the same, heavy-duty (4000) is manufactured with a 5/8"-18 x 1" long thread solid steel support rod while the standard (3000) contains a 1/8" x 1" long thread NPT pipe size support rod.

To clean, simply remove from reservoir and wipe with a clean cloth every 3 to 6 months.

Order pipe plugs separately. Pipe plugs for installing in the top of the reservoir are optional and are furnished in 3/4" and 1 1/4". If space is available, it is recommended that the 1 1/4" plug be used for ease of removal.

3/4" Plug Part No.

12P (For 1/8" NPT Rod)

HD 12P (For 5/8"-18 Rod)

1 1/4" Plug Part No.

20P (For 1/8" NPT Rod)

HD 20P (For 5/8"-18 Rod)

Note** Special Rod Lengths Available

Standard Slim Line 3000 Series

MODEL NO.		A	B
3002	IN	6"	11"
	MM	152	279
3003	IN	8.5"	13.5"
	MM	216	343
3004	IN	11"	16"
	MM	279	406
3005	IN	13.5"	18.5"
	MM	343	470
3006	IN	16"	21"
	MM	406	533
3007	IN	18.5"	23.5"
	MM	470	597
3008	IN	21"	26"
	MM	533	660
3009	IN	23.5"	28.5"
	MM	597	724
3010	IN	26"	31"
	MM	660	787

Heavy Duty Slim Line 4000 Series

MODEL NO.		A	B
4002	IN	5.8"	10.8"
	MM	147	274
4003	IN	8.3"	13.3"
	MM	211	338
4004	IN	10.8"	15.8"
	MM	274	401
4005	IN	13.3"	18.3"
	MM	338	465
4006	IN	15.8"	20.8"
	MM	401	528
4007	IN	18.3"	23.3"
	MM	465	592
4008	IN	20.8"	25.8"
	MM	528	655
4009	IN	23.3"	28.3"
	MM	592	719
4010	IN	25.8"	30.6"
	MM	655	777

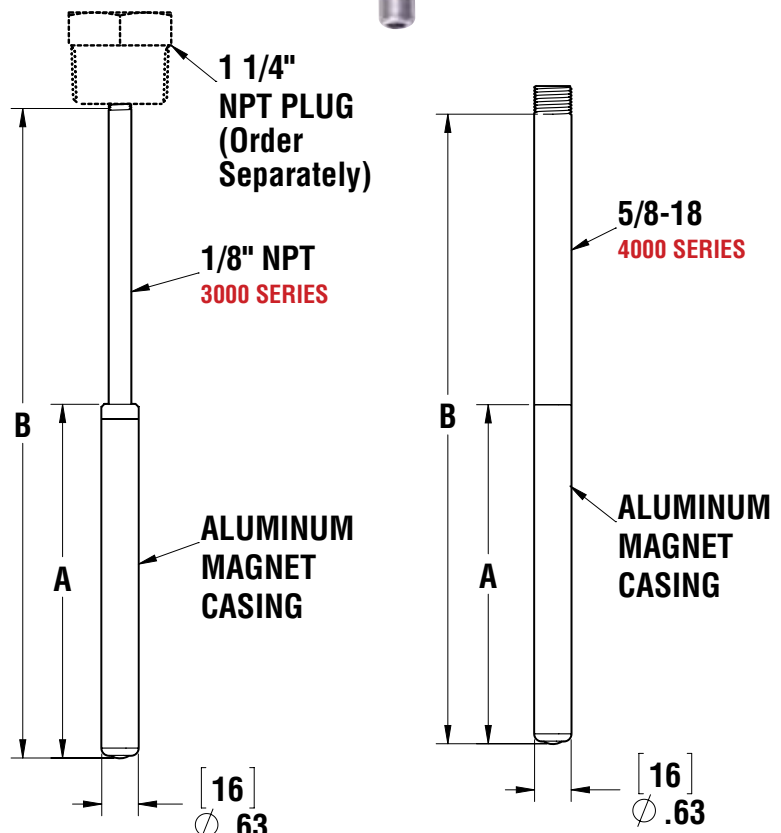

WF Weld Flange
See page 48a

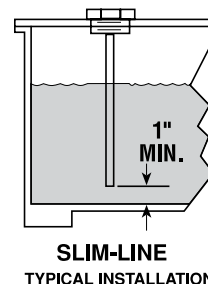

Steel Support Rods are 12L14
Stainless Support Rods are 303CD

SLIM-LINE
TYPICAL INSTALLATION