



Diesel Filler Necks

Lenz diesel fill necks are fabricated from heavy gauge steel. With 1 optional lock tab, stainless steel fill screens available. The caps can be ordered in vented or non-vent, with optional lock tab, each having a diaphragm or deflector to reduce spillage.

Diesel Fill Necks

HDF Series-Diesel Fuel Applications

- 16 gauge (.060") steel
- Tube extension .12" wall thickness, 2.6" O.D.
- 1.3", 3", 6", 8" standard straight cut lengths
- Chain anchor is in the neck, and chain is shipped with neck

Options

- Stainless steel, aluminum available (25 Piece minimum)
- Lock tab available
- Overflow tube
- Threaded 2" NPT connection
- 52 angle cut (25 piece minimum)
- 20 or 40 mesh 4.5" length fill screens recommended to be ordered separately in order to allow for welding and powder coating of neck
- SR option is required when ordering to allow for screen to be used
- 4.5 option code means screen will be assembled at factory
- Fuel flapper, with fuel flapper screen not available

"Our customers have suggested that we Offer necks, caps, and screens separately because of the need to weld and paint some items. If you want to order a completely assembly consult the factory for part numbers."

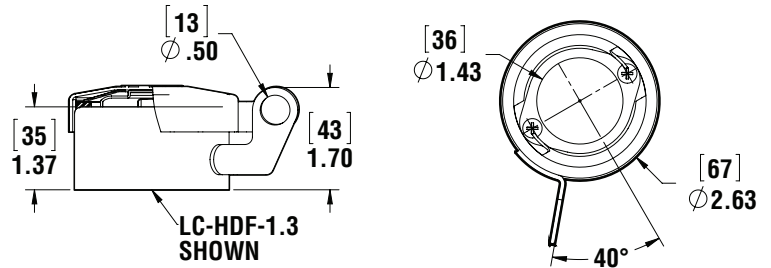

Model Number	Length A	
	in.	See Drawing
HDF-1.3	in.	See Drawing
	mm	
HDF-603	in.	3"
	mm	76
HDF-606	in.	6"
	mm	152
HDF-608	in.	8"
	mm	204
HDF-6**	in.	Custom Length
	mm	

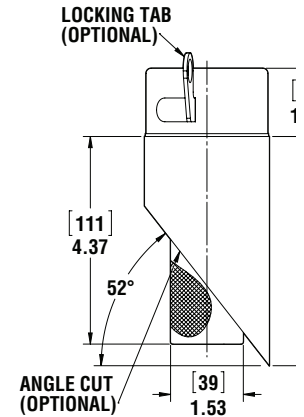

Neck Ordering Code

LC - ALUM - HDF - 603 - 52 - 4.5 - 20M - SR



Omit	Standard
LC	Locking Tab

Material	
Omit	Steel
*Alum	Aluminum

Series
HDF

Neck Length	
1.3	1.37" Neck (NO SR OPTION)
603	3" Neck
606	6" Neck
608	8" Neck
6**	Specify

Other Options	
Omit	No Added Options
SR	Screen Retainer
OF	Overflow Tube
FL	Flapper

Screen Mesh	
Omit	40 Mesh
20M	20 Mesh

Screen	
Omit	No Screen
4.5	Screen Installed

Angle	
Omit	Straight
52	52° Angle

*Minimum quantity required consult LENZ.



HDF-1.3 Series

Specifications

- 16 gauge (.060) steel
- 1.3" standard length
- Chain anchor is in the neck, and chain is shipped with neck

Options

- Lock tab available
- 20 or 40 mesh 4.5" length fill screens recommended to be ordered separately in order to allow for welding and powder coating of the neck
- SR option is required when ordering to allow for screen to be used
- 4.5 option code means screen will be assembled at factory



LC-HDF-1.3

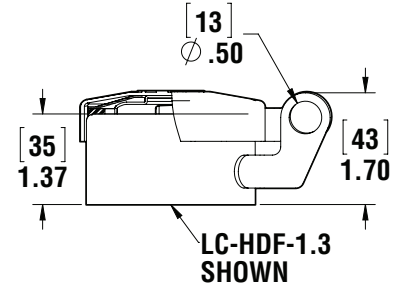

Diesel Fill Screen

- 20 or 40 mesh available
- 4.5" long, 1.52" diameter
- 2 bolt flange for mounting to neck
- (2) 6/32 x 3/8" P.H.M.S. included with screen



HDS-4.5-20M

Screen Ordering Code

HDS		—	4.5	—	20M
Series			Length		Mesh
HDS			4.5"		40 Mesh
					20 Mesh

6 Series

Diesel Fill Caps

- Steel zinc plated standard
- Vented or non vented available
- Buna gasket standard
- Optional Viton gasket
- Green Powder cap optional
- S-Hook comes standard on cap



LC-6NV-GR



6V

Cap Ordering Code

LC		—	6V	—	*
Omit	Steel		Cap Function		Options
Omit	No Lock		6V	Vent	Omit
LC	Lock Tab		6NV	Non Vented	GR
					DIP
					VIT

Zinc plating is standard finish on cap.

25pc. minimum on dipstick option
25pc. minimum green

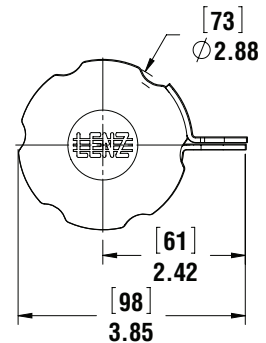
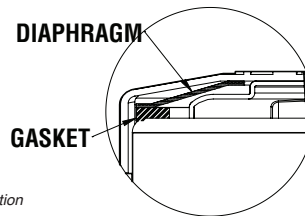

CARB/EPA compliant filler caps

The Lenz 6-NV-Viton cap is CARB/EPA compliant. The all steel construction cap is equipped with the Viton gasket prevents fluid permeation. The positive stop ¼ turn bayonet design provides physical feedback that a seal has been established and negates the need for an audible feedback requirement required on threaded caps. Our chain which is specified on the neck allows the cap to be tethered to the fill neck as a part of the tank. The Lenz Viton gasket is compatible with most fuels and fluids and provides a good fuel vapor seal.

See Technical Bulletin TB.TA04.708 and TB.TA17.708 for further information at (Technical Data - www.lenzinc.com).