



Bayonet Filler Breather Caps

Model LGB-B Series

Specifications

- Maximum flow rate 68 CFM, 576 GPM @ .18 PSI
- Steel canister
- 3 or 10 micron phenolic resin impregnated paper
- Nylon bayonet adaptor B-12, B-752
- Aluminum adaptor B-128
- 3"-30 mesh SS basket standard
- SAE J 829 steel zinc plated mounting flange
- Buna tab gaskets standard
- Cork-rubber flange gaskets standard
- 10-24 x 1/2" thread forming screws standard
- Operating temperature -22°F to +212°F (-30°C to +100°C)
- Compatible with petroleum and mineral based fluids



LGB-B12-10
(Replacement Breather)



LGB-B752-10



LGB-752-10 -3-30

LGB Series Performance Graphs

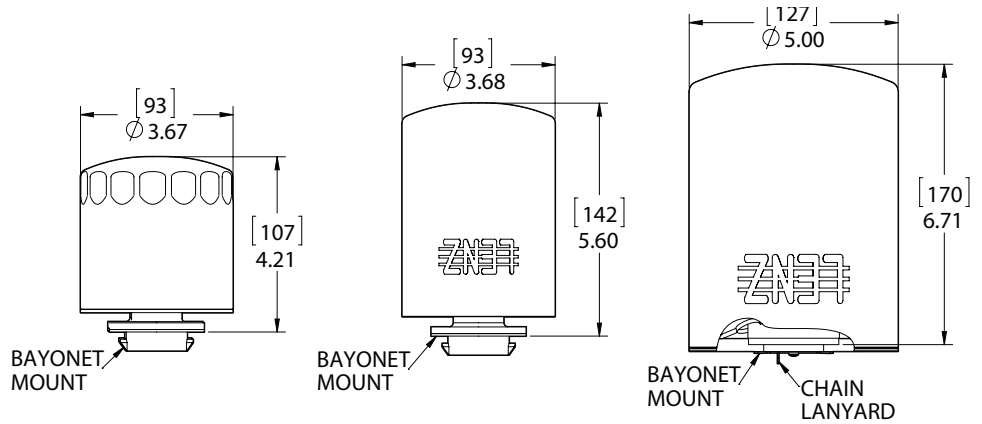
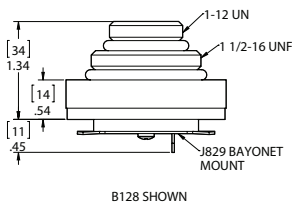
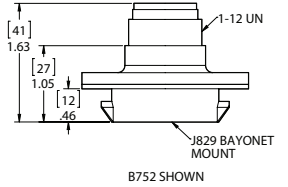
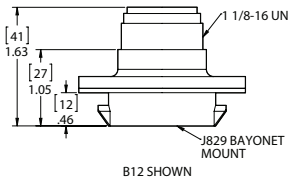
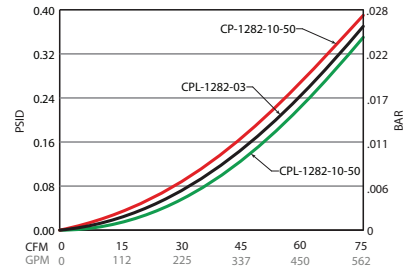
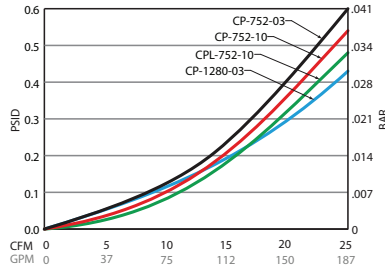
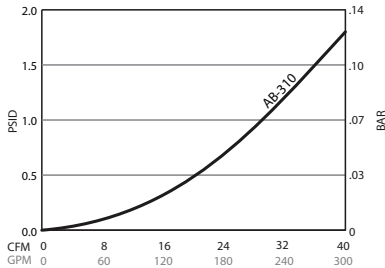

Assembly Ordering Code

LGB - B-12 - 10 - N - *

LGB Breathers	Bayonet	Element Series	Microns	Omit	No Screen	Omit	None
	B-752	CP-752	3	2-30	2"-30 Mesh	10-32	10-32 Screws
	B-128	CP-1282	10	3-30	3"-30 Mesh	LCH	Less Chain
	B-12	CP-AB-310	10L	3-100	3"-100 Mesh	buna	Rubber Gasket
				6-30	6"-30 Mesh	1.5 HN	1.5" High Neck
				6-100	6"-100 Mesh	3 HN	3" High Neck
				8-30	8"-30 Mesh	IG3	3" Inner Gaurd
				8-100	8"-100 Mesh	IG6	6" Inner Gaurd
				13-30	13"-30 Mesh	IG8	8" Inner Gaurd
				N	3.8" 30 Mesh	IG13	13" Inner Gaurd

Model	Rated CFM	Rated GPM	Bayonet Adaptor
CP-AB-310	40	300	B-12
CP-752-03	15	113	B-752
CP-752-10	17	127	B-752
CPL-752-10	18	134	B-752
CP-1282-03-50	51	382	B-128
CPL-1282-03-50	58	433	B-128
CP-1282-10-50	54	405	B-128
CPL-1282-10-50	68	576	B-128



Bayonet Cap Mounting Options

FCS-537 Series



XL Series



FCS-557 Series



NY Series



Weld on Neck
4.5" Neck Fill Screens



LGB Series

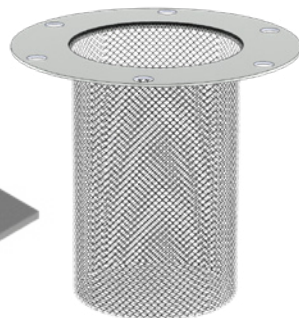
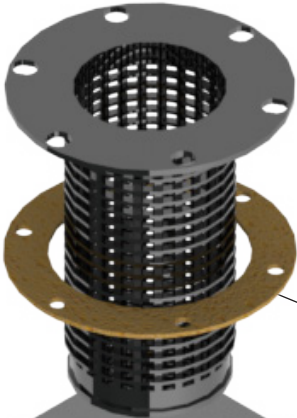
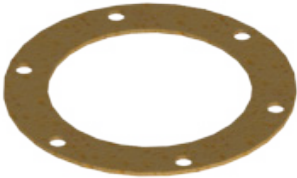

2" to 13" Screens Available
See page 3b

Using Tank Flange



Black Powder Coated
 Catalog page 5b
 Weather-proof application
 Example when ordering:
 BPC-57-XL-40



Locking Caps
 Catalog page 5b
 Prevents tampering with equipment
 Example when ordering:
 LC-57-XL-40 / LD-57-XL-40



Pressurized Breather
 Catalog page 6b
 3, 5, 10 P.S.I. double valve
 Example when ordering:
 57-XL-40-P5



3" & 1.5" High Neck Flange
 Catalog page 3b
 Oil containment application
 Example when ordering:
 5-1.5HN, 5-3HN



Weld Riser
 Catalog page 4b
 Rises filler breather 1"
 Example when ordering:
 LWR-1



Hydraulic Weld Necks
 Catalog page 11-12b
 Weld on neck allows for mounting breather
 Example when ordering:
 LC-HYD-405-4.5 \ HYD-125



Anti-Splash Breather
 Catalog page 5b
 Oil containment application
 Example when ordering:
 AS-57-XL-40



Breathers With Dipsticks
 Catalog page 5b
 Allows for checking oil level
 Example when ordering:
 57-XL-40-DIP / BPC-57-XL-40-DIP



Non Breather
 Catalog page 8b
 Non breathing cap
 Example when ordering:
 FCS-557



Side Mount Breather
 Catalog page 4b
 Allows mounting breather on side of reservoir
 Example when ordering:
 SM-57-XL-40



Nylon Filler Breather
 Catalog page 9b
 Bayonet non metal cap
 Example when ordering:
 NY-B-40



Bayonet Filter Breather
 Catalog page 10b
 Bayonet filter breather
 Example when ordering:
 LGB-B12-10-3-30



6 Bolt bayonet Flange

These SAE J829 tank mounted filler breathers are used as a fill port on reservoirs. Lenz breathers filter out contaminants when filling the reservoir, and airborne contaminants as the system is operating. Over the next few pages Lenz offers various components you can select when designing your filler breather assembly.

Bayonet Filler Breather Components

Steel Zinc Plated or Epoxy coated flanges

- SAE J829 mounting flange
- 1/2" height, (5 flange)
- 1 1/2" height, (5-1.5 HN)
- 3" height, (5-3 HN)

Stainless Steel Baskets (304 S.S)

- 7-2-30 2" O.A.L. 30 mesh stainless screens, steel zinc plated flange
- 7-3-30 3" O.A.L. 30 mesh stainless screens, steel zinc plated flange
- 7-3-100 3" O.A.L. 100 mesh stainless screens, steel zinc plated flange
- 7-6-30 6" O.A.L. 30 mesh stainless screen, steel zinc plated flange
- 7-6-100 6" O.A.L. 100 mesh stainless screen, steel zinc plated flange
- 7-8-30 8" O.A.L. 30 mesh stainless screen, steel zinc plated flange
- 7-8-100 8" O.A.L. 100 mesh stainless screen, steel zinc plated flange
- 7-13-30 13" O.A.L. 30 mesh stainless screen, steel zinc plated flange

Nylon Basket

- 7-N 3.8" O.A.L. 30 mesh polypropylene screens

Basket Inner Guards

- Steel perforated metal, steel zinc plated flange
- 7-3 inner guard 3" basket, steel zinc plated flange
- 7-6 inner guard 6" basket, steel zinc plated flange
- 7-8 inner guard 8" basket, steel zinc plated flange
- 7-13 inner guard 13" basket, steel zinc plated flange

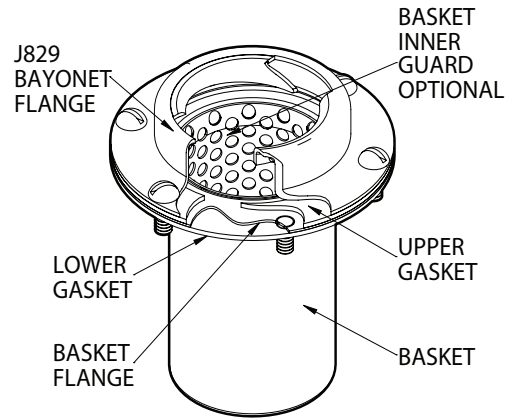

Bayonet Flange

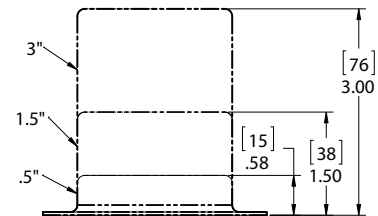

Stainless Baskets

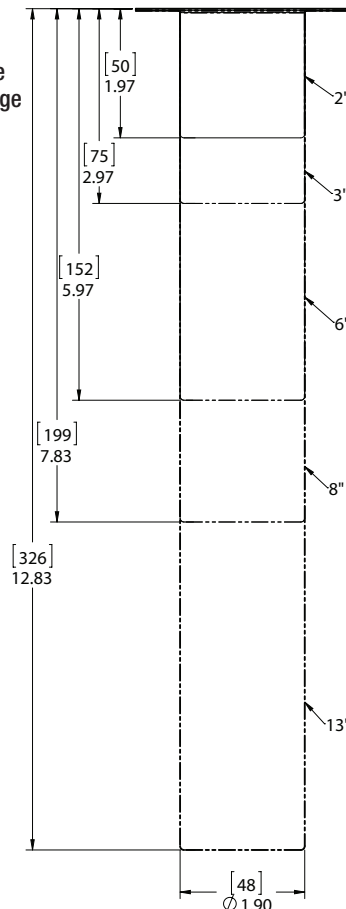

Basket Inner Guard

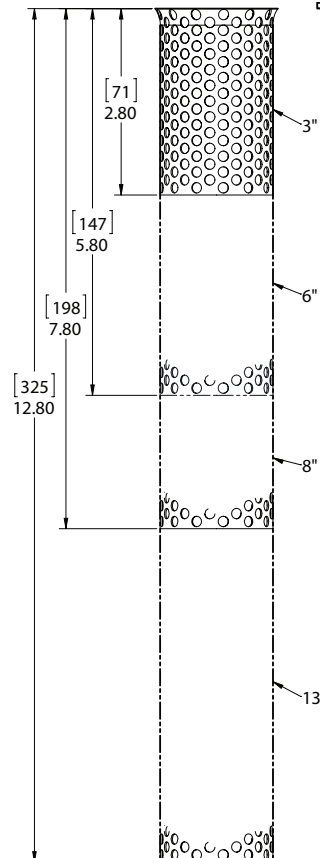

Nylon Basket

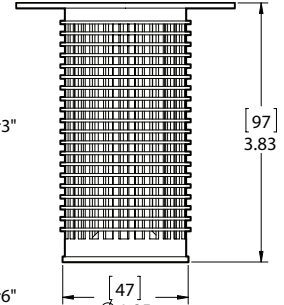



Bayonet Gaskets

- Cork-rubber flange gaskets (8 cork gasket)
- Buna rubber flange gaskets (8 buna gasket)
- Cork-rubber tab gasket (XL gasket cork)
- Buna rubber tab gasket (XL gasket buna)

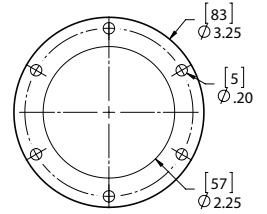

Bayonet Screws

- 10-24 x 1/2" steel zinc finish self thread forming #9 screws (qty.6)
- 10-32 x 1/2" steel zinc finish slotted round head machine screw
- 10-24 x 1/2" stainless 18-8 self thread forming screw



Side Mount Filler Cap Assemblies

Filler Strainer Breather Model SM

Filters, Breathes and Strains - Makes hydraulic fuel tank customizing easier. Designed for use on tanks that require filling from the end or side. Choice of standard or weather-proof cap (same as Model FCS) at no extra charge. Fully assembled and ready to mount. Includes instructions and template. May also be welded directly to side of reservoir.

LENZ Quality Standards - Heavy-duty design, one-piece housing is of steel. Six bolts with nuts and seals and mounting gasket are included. All other components and specifications are identical to those for LENZ Standard FCS Model or 57XL (Page 1b). Zinc or black powder coated oxide finish optional at additional cost. Separate housings, SMW unplated, are also available.

BOLT-ON OPTION



WELD-ON OPTION UNPLATED

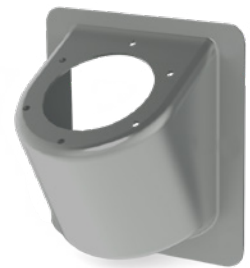

Assembly Ordering Code

SM - AS - 57XL - 40 - 3 - 100 - 3 HN

Omit	(Standard)
SM	Side Mount
WO-SM	Weld On

Choose the desired style filler breather cap

57-XL Series Ordering Code, see page 3b
FCS 557 Series Ordering Code, see page 6b
FCS 537 Series Ordering Code, see page 5b
NY-B Series Ordering Code, see page 7b
LGB Series Ordering Code, see page 8b

Only the 3" Stainless basket can be used with the SM series.

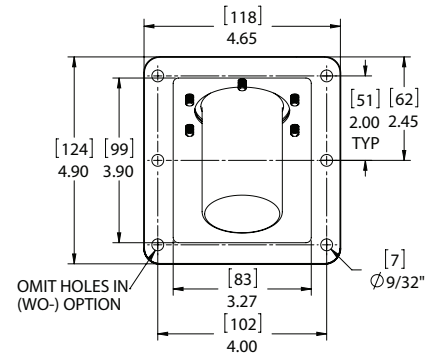
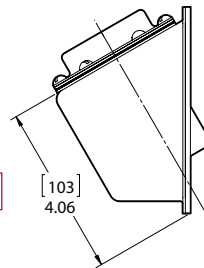

Weld Neck Risers

Model LWR

The "LWR" series Weld Neck Risers are designed to raise filler breather assemblies up to 1" above the surface of the tank top. This low cost riser eliminates costly repairs brought on by contamination and water being swep into the reservoir.

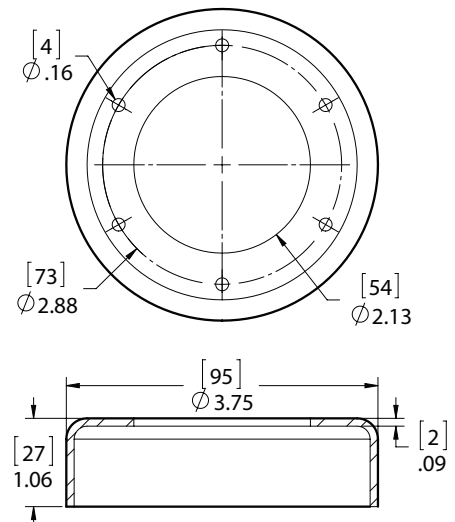

Model	Material	Height
LWR-1	Steel	1 1/16"
LWR-1-ALUM	Aluminum	1 1/16"
LWR-1-SS	304 Stainless Steel	1 1/16"